

BiPAC 5200N *RC*

Wireless-N ADSL2+ Firewall Router

Quick Start Guide



PLEASE READ THE QUICK START GUIDE AND FOLLOW THE STEPS CAREFULLY. THIS QUICK START GUIDE WILL HELP YOU INSTALL THE DEVICE PROPERLY AND AVOID IMPROPER USAGE. IF YOU NEED MORE INFORMATION ON THIS SOFTWARE CONFIGURATION, PLEASE REFER TO THE USER MANUAL ON THE CD-ROM.

Package Contents

- BiPAC 5200N RC ADSL2+ Firewall Router
- CD containing the on-line manual, utility and QSG
- RJ-11 ADSL/ telephone cable
- Ethernet (RJ-45) cable
- Power adapter
- Quick Start Guide
- Splitter/ Micro-filter (Optional)

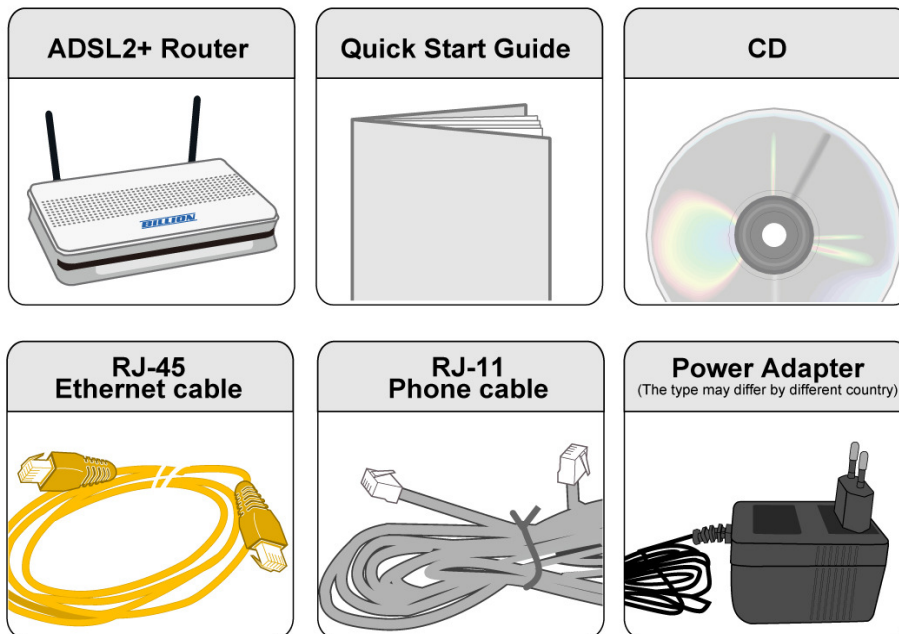

Warning

- Do not use the router in high humidity or high temperatures.
- Do not use the same power source for the router as other equipment.
- Do not open or repair the case yourself. If the router is too hot, turn off the power immediately and have it repaired at a qualified service center.
- Avoid using this product and all accessories outdoors.



Attention

- Place the router on a stable surface.
- Only use the power adapter that comes with the package. Using a different voltage rating power adaptor may damage the router.

Hardware Overview

The Front LEDs

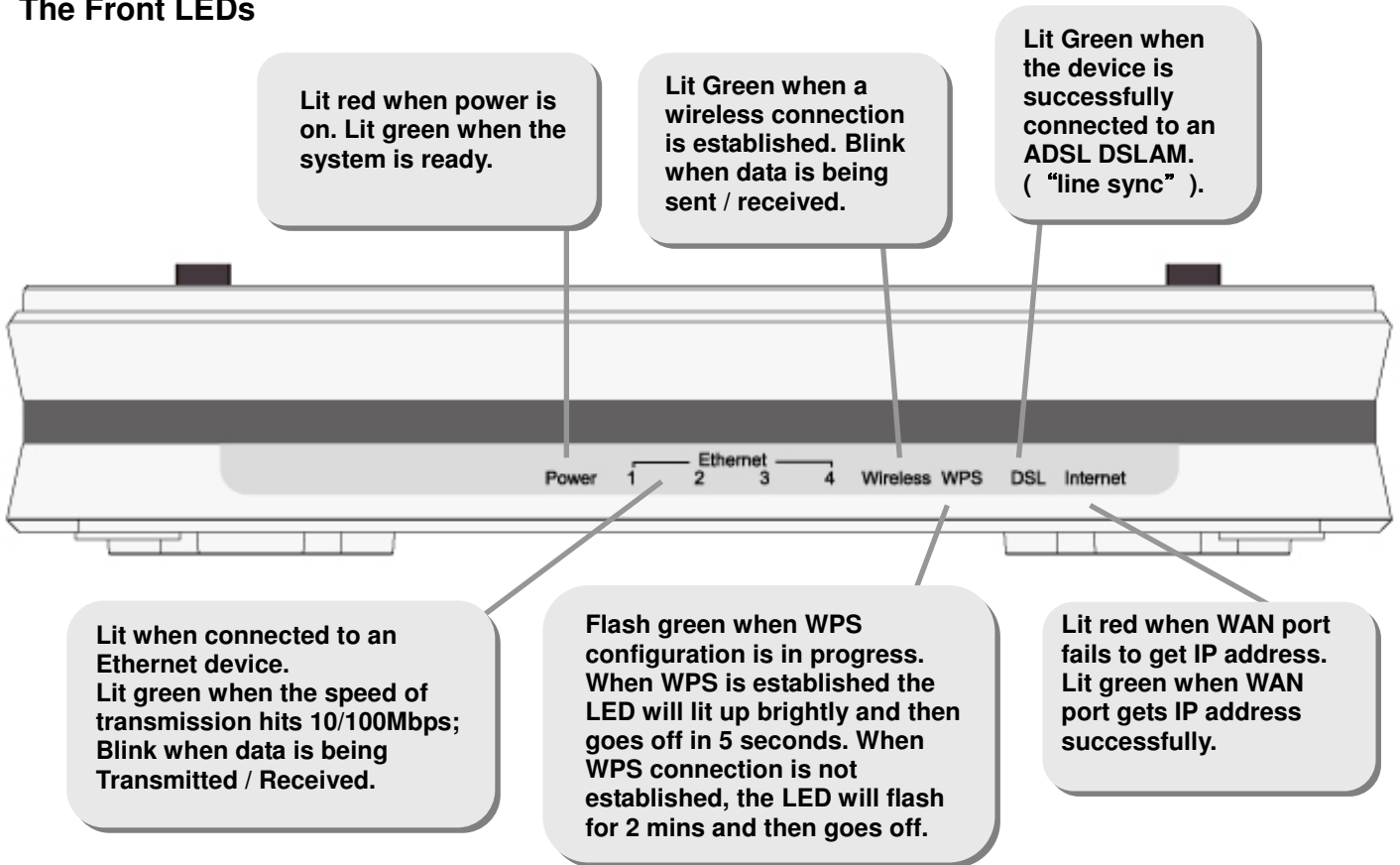

The Rear Ports

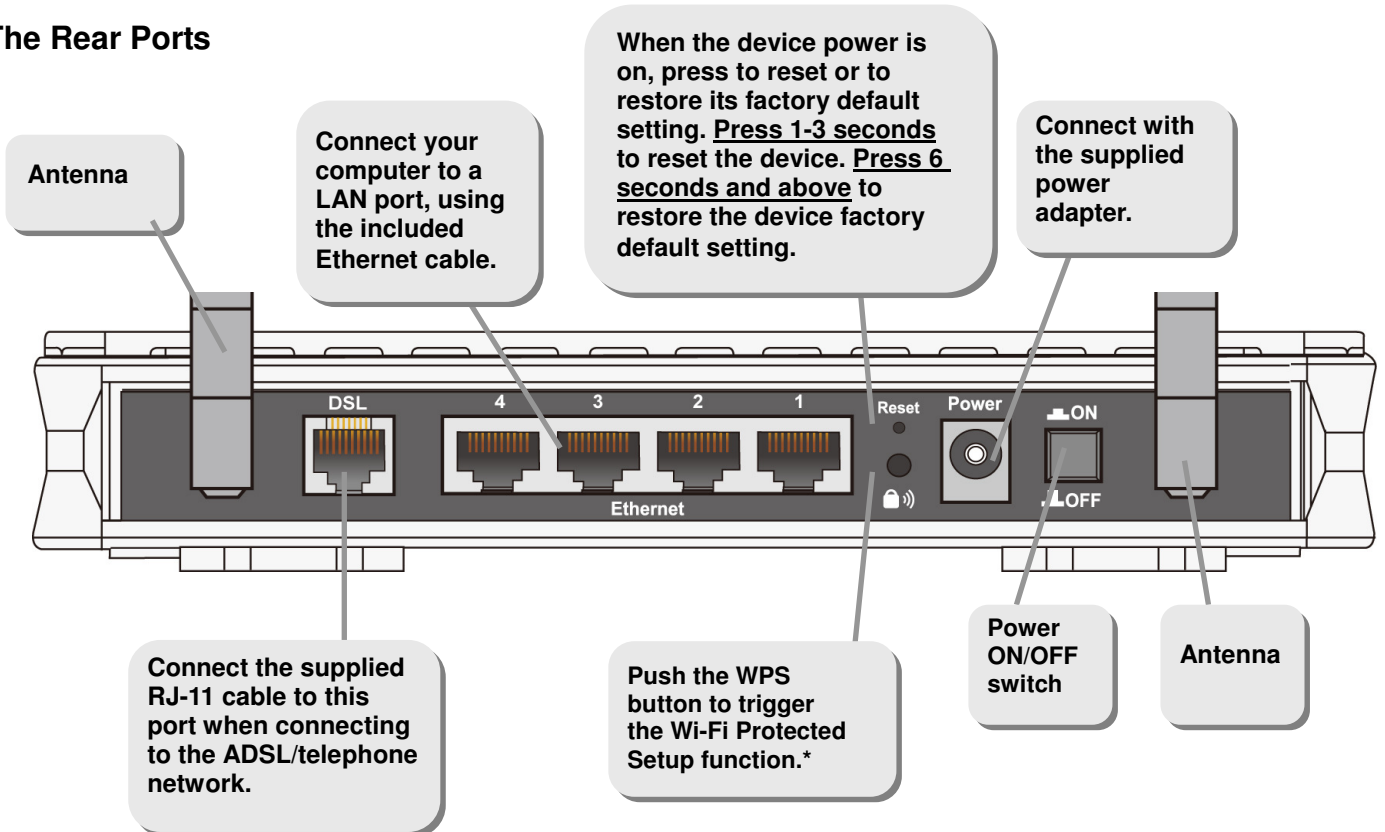

* Note: For WPS configuration, please refer to the WPS section of User Manual.

Hardware Connection

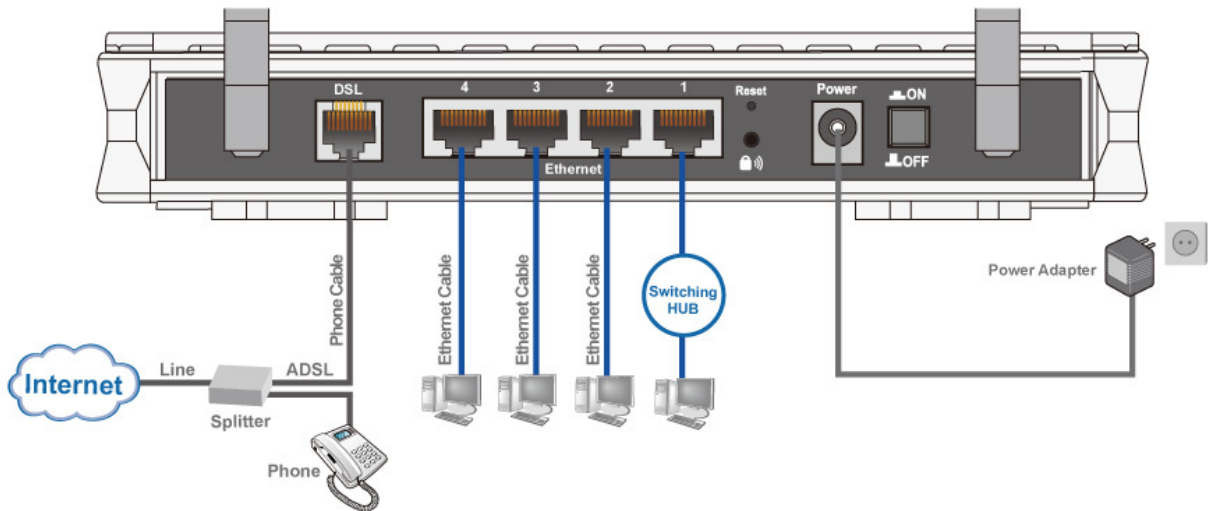

Hardware Installation

1. Power Connection

Plug the supplied power adapter to the wall jack and the other side to the router. Please note that the plug type may differ according to country.

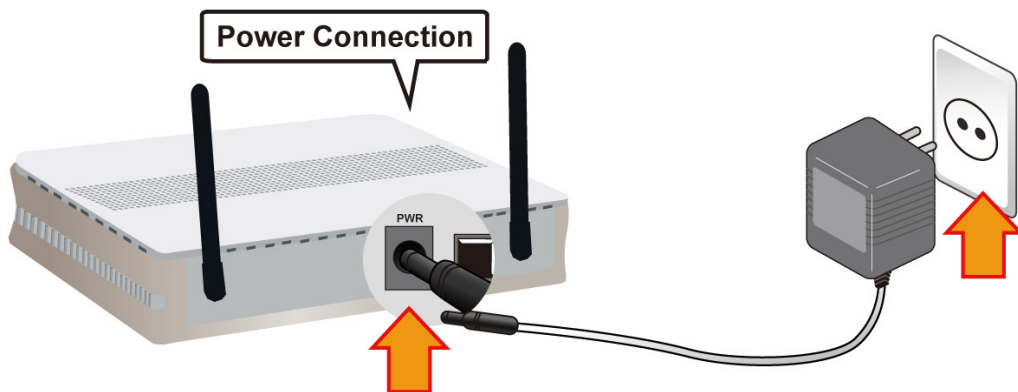

2. LAN Connection

Connect the supplied RJ-45 Ethernet cable to one of the Ethernet ports, and the other side to the PC's Ethernet interface.

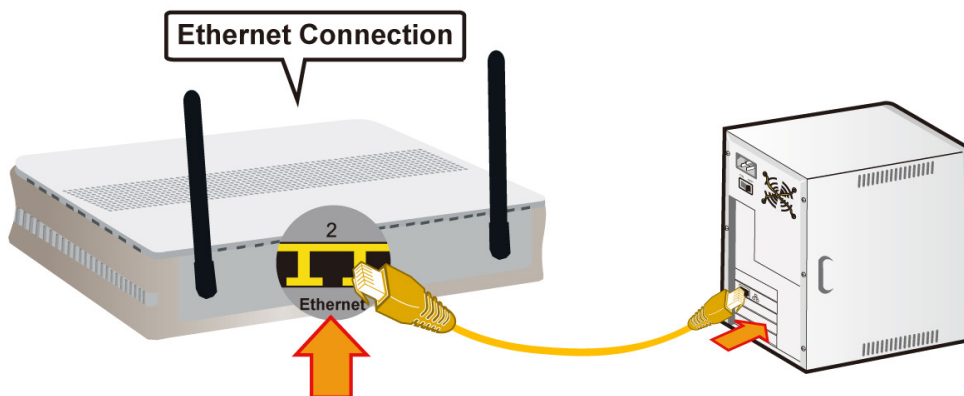

3. ADSL Connection

Connect the supplied RJ-11 phone cable to the router's ADSL port, and the other side to the phone jack on the wall.

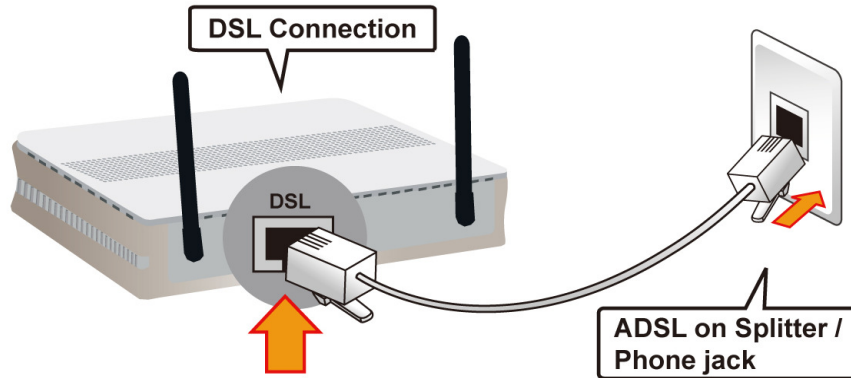

4. Splitter/ Micro-filter Connection

Splitter / Micro-filters are important for ADSL installation, they help ensure that high-frequency signals are directed to the ADSL modem, and low-frequency signals are directed to the telephone or other analog voice-channel device to prevent inter-modulation distortion and get good speeds and stable ADSL sync rate.

a) Splitter connection

If the installation has only a single telephone and a single ADSL modem, then a splitter can be employed.

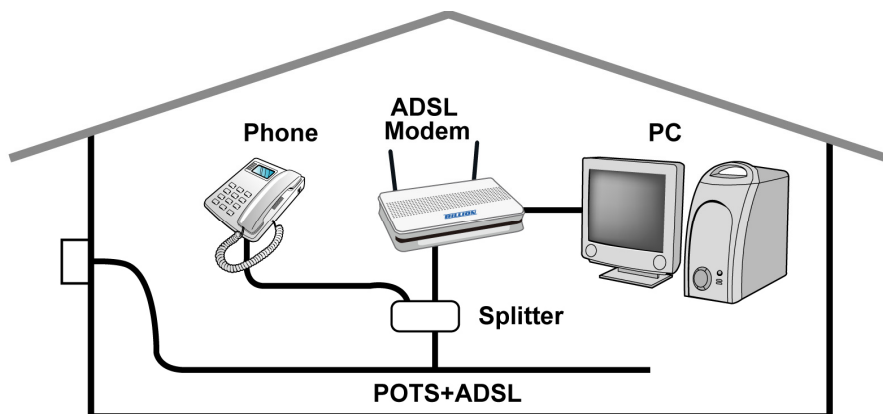

b) Micro-filter connection

If the installation has several telephones or other analog devices, then an internal micro-filter can be employed at each analog device.

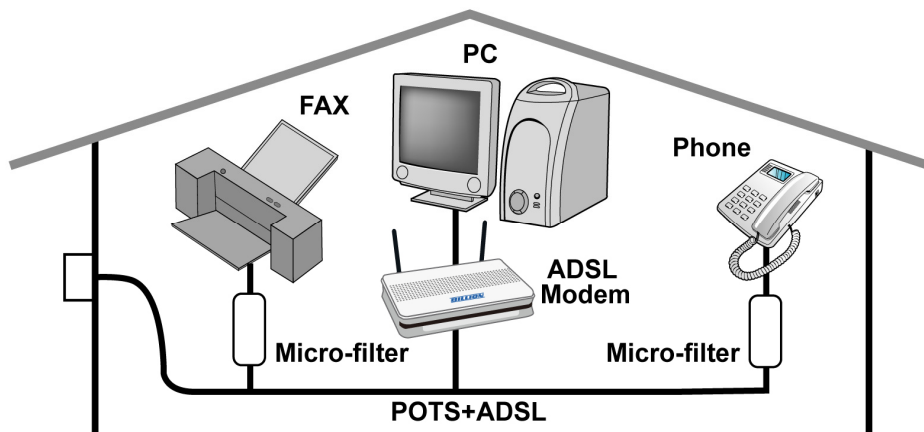

Setup Utility

After you complete the hardware installation insert CD into the CD Drive to run the setup utility. The setup utility will auto-run. Follow the step-by-step configuration wizard & it will guide you to setting up the basic network configuration.

Connecting to the Router

1. Open the web browser and type <http://192.168.1.254> in the browser's address box. This number is the default IP address for this router. Press **Enter**.
2. A username and password window will appear. The default **username is "admin"**, **password is "admin"**. Press **OK** to proceed.
3. You will get a status report web page and main menu screen.

Please see the relevant sections of user manual for detailed instructions on how to configure your router.

Troubleshooting

1. **None of the LEDs are on when you turn on the router.**
Check the connection between the adapter and the router. If the error persists, you may have a hardware problem. In this case you should contact technical support.
2. **Can't ping any PCs on the LAN.**
Check the Ethernet LEDs on the front panel. The LED should be on for a port that has a PC connected. If it is off, check the cables between your router and the PC. Make sure you have uninstalled any software firewall for troubleshooting. Verify that the IP address and the subnet mask are consistent between the router and the workstations.
3. **Frequent loss of ADSL linesync (disconnections).**
Ensure that all other devices connected to the same telephone line as your router (e.g. telephones, fax machines, analogue modems) have a line filter connected between them and the wall socket (unless you are using a Central Splitter or Central Filter installed by a qualified and licensed electrician), and ensure that all line filters are correctly installed and the right way around. Missing line filters or line filters installed the wrong way around can cause problems with your ADSL connection, including causing frequent disconnections. If you have a back-to-base alarm system you should contact your security provider for a technician to make any necessary changes.

Product Support and Contact Information

Most problems can be solved by referring to the **Troubleshooting** section in the User Manual. If you cannot resolve the problem with the **Troubleshooting** chapter, please contact the dealer where you purchased this product.

Contact Billion

WORLDWIDE

<http://www.billion.com>

Billion Product Registration

Billion is committed to before and after sales customer services. You will get the most out of your Billion's products after registration. Please register online at <http://www.billion.com/register> to receive valuable services and support from us.