

BiPAC 9800(N)

(802.11n) Fiber Optical Router

Quick Start Guide

Declaration of Conformity

in accordance with the Radio and Telecommunications Terminal Equipment Act (FTEG)
and Directive 1999/5/EC (R&TTE Directive)

The Manufacturer: *Billion Electric Co., Ltd.*
*8F, No. 192, Sec. 2, Chung Hsing Rd.,
Hsin Tien City, Taipei Hsien*

declares that the product: *BiPAC 9800N 1000Base-SFP, BiPAC 9800N 100Base-SFP,
BiPAC 9800N 1000Base-BX, BiPAC 9800N 100Base-BX,
BiPAC 9800N 1000Base-LX, BiPAC 9800N 100Base-LX,
BiPAC 9800N 100Base-FX, BiPAC 9800 100Base-FX,
BiPAC 9800 1000Base-SFP, BiPAC 9800 100Base-SFP,
BiPAC 9800 1000Base-BX, BiPAC 9800 100Base-BX,
BiPAC 9800 1000Base-LX, BiPAC 9800 100Base-LX,

Radio equipment*

Intended purpose: *(802.11n) Fiber Optical Router*

complies with the essential requirements set out in the Council Directive on the Approximation of the
Laws of the Member States relating to Radio Equipment and Telecommunications Terminal Equipment
Directive (1999/5/EC), when used for its intended purpose.

Harmonised standards: Health and Safety requirements

EN 60950-1: 2006

IEC 60950-1: 2005

Harmonised standards: Protection requirements with respect to EMC

EN 55022: 2006 + A1: 2007

EN 61000-3-2: 2006

EN 61000-3-3: 1995 + A1: 2001 + A2: 2005

EN 55024: 1998 + A1: 2001 + A2: 2003 (IEC 61000-4-2: 1995 + A1: 1998 + A2: 2000; IEC 61000-4-3: 2006; IEC 61000-4-4: 2004; IEC 61000-4-5: 2005; IEC 61000-4-6: 2003 + A1: 2004 + A2: 2006; IEC 61000-4-8: 1993 + A1: 2000; IEC 61000-4-11: 2004)

ETSI EN300 328 V1.7.1: 2006

Interface specification: Air interface of the radio systems:

2.412 – 2.472 GHz

London
(Place)

11 Feb / 2007
(Date)

Edward Kung
Managing Director
Etec Components Ltd.



PLEASE READ THE QUICK START GUIDE AND FOLLOW THE STEPS CAREFULLY. THIS QUICK START GUIDE WILL HELP YOU INSTALL THE DEVICE PROPERLY AND AVOID IMPROPER USAGE. IF YOU NEED MORE INFORMATION ON THIS SOFTWARE CONFIGURATION, PLEASE REFER TO THE USER MANUAL ON CD-ROM.

Package Contents

- BiPAC 9800(N) (802.11n) Fiber Optical Router
- CD containing the on-line manual
- Ethernet (RJ-45) cable
- Three 2dBi detachable antennas (BiPAC 9800N only)
- Power adapter
- This Quick Start Guide

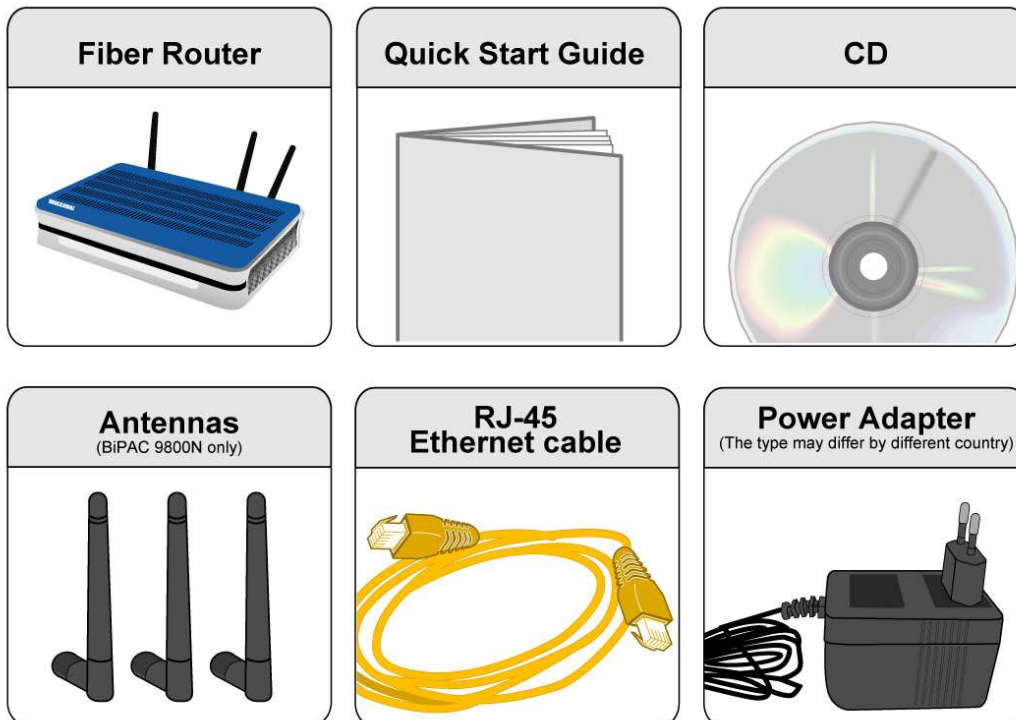

Warning



Attention

- Do not use the router in high humidity or high temperatures.
- Do not use the same power source for the router as other equipment.
- Do not open or repair the case yourself. If the router is too hot, turn off the power immediately and have it repaired at a qualified service center.
- Avoid using this product and all accessories outdoors.
- Place the router on a stable surface.
- Only use the power adapter that comes with the package. Using a different voltage rating power adaptor may damage the router.

Hardware Overview

The Front LEDs

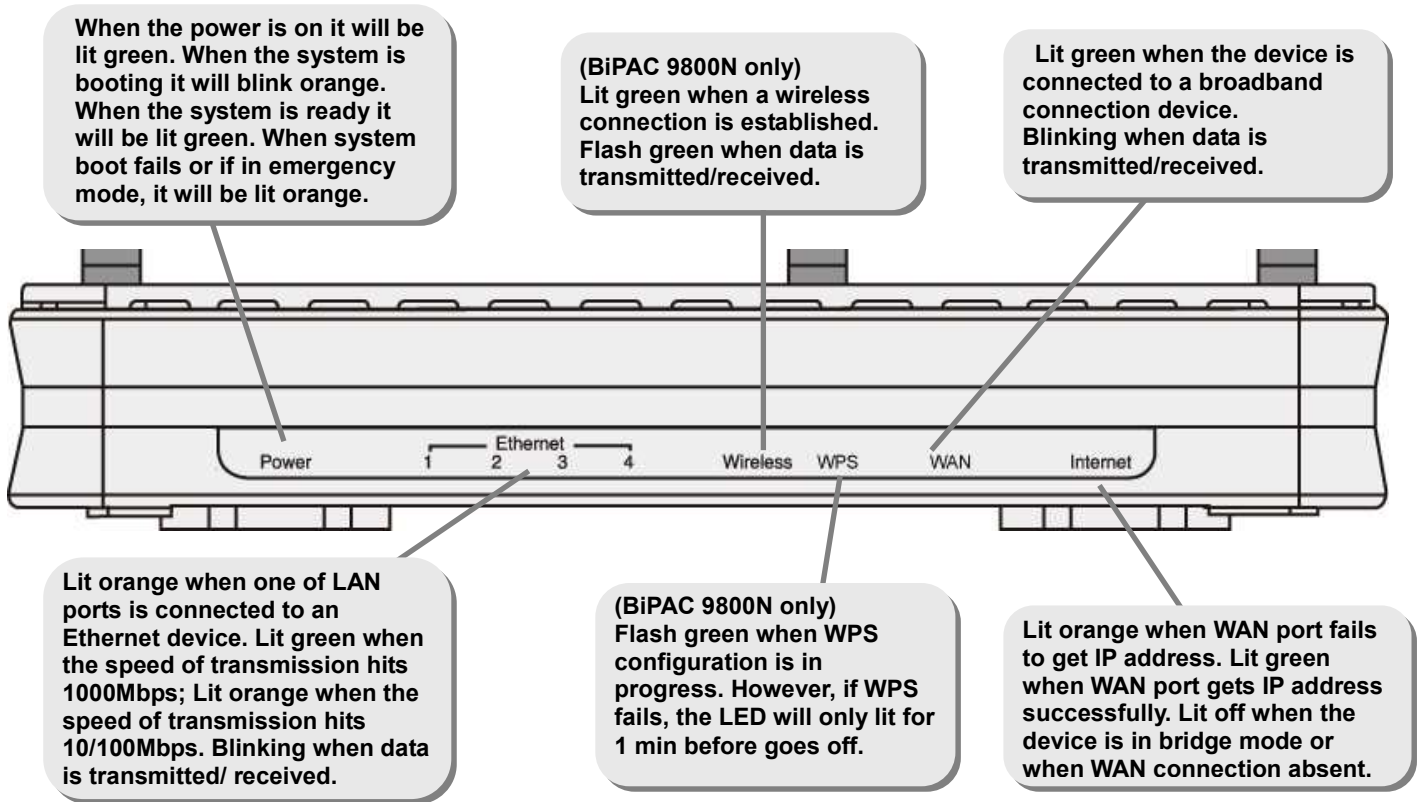

The Rear Ports

Single SC Port

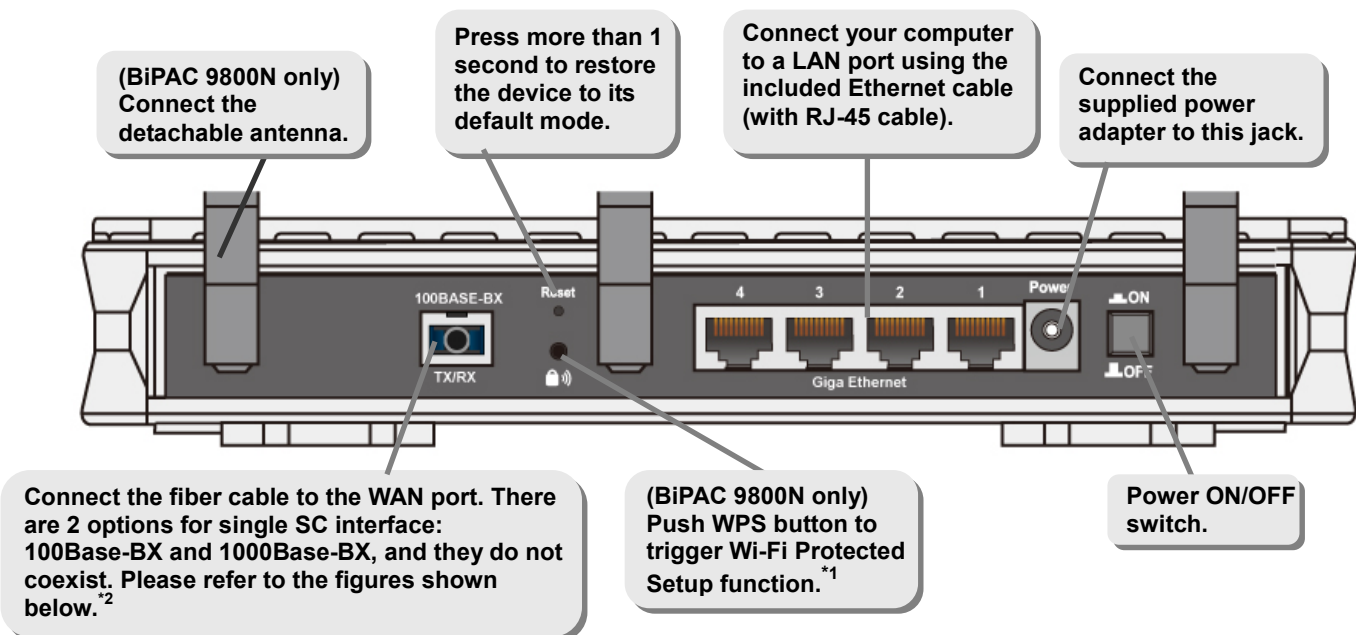



- 100BASE-BX: A single strand of optical fiber. Single-mode fiber is used. It supports SC connector.



- 1000BASE-BX: A single strand of optical fiber. Single-mode fiber is used. It supports SC connector.

Dual SC Ports

Dual fiber WAN interface is separated into single-mode and multi-mode.

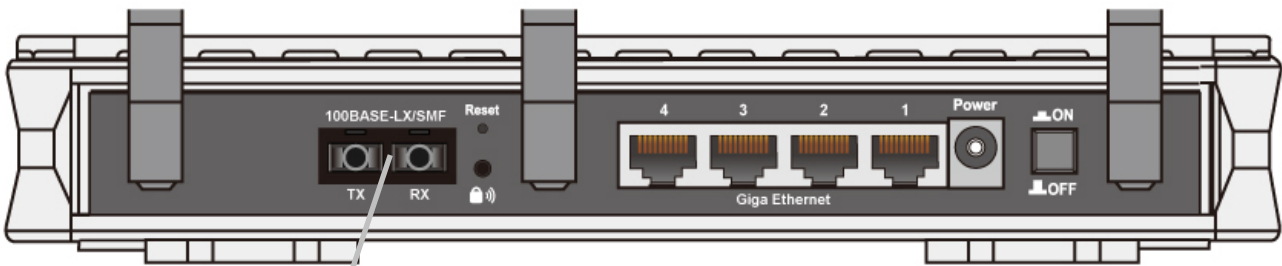

Connect the fiber cable to the WAN port. There are 3 options for dual SC interface: 100Base-LX/ SMF, 1000Base-LX/SMF and 100Base-FX/MMF, and they do not coexist. Please refer to the figures shown below.²



- 100BASE-LX/SMF: Two strands of optical fiber, one for receive (RX) and the other for transmit (TX). Single-mode fiber is used. It supports SC connector.



- 1000BASE-LX/SMF: Two strands of optical fiber, one for receive (RX) and the other for transmit (TX). Single-mode fiber is used. It supports SC connector.



- 100BASE-FX/MMF: Two strands of optical fiber, one for receive (RX) and the other for transmit (TX). Multi-mode fiber is used. It supports SC connector.

SFP Port

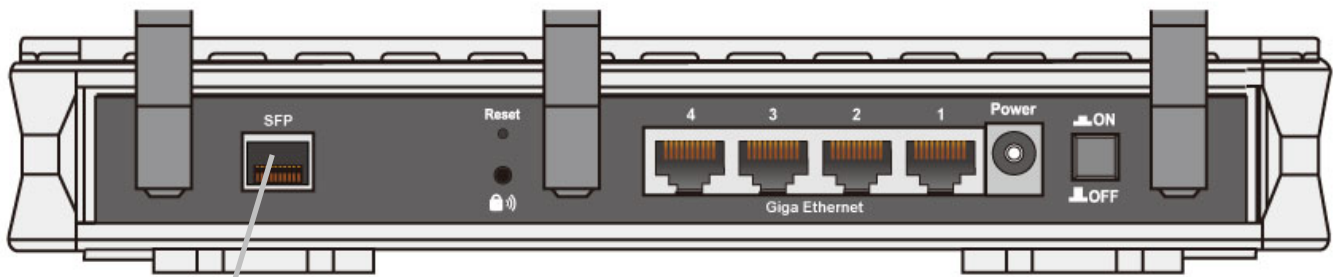

Install the Mini-GBIC module into the SFP cage. Connect the fiber cable to the fiber port of Mini-GBIC module. We offer 2 types of SFP interfaces: 100Base-SFP and 1000Base-SFP, and they do not coexist. Please refer to the figure shown below.*²



A cage for SFP (Small Form-Factor Pluggable) transceiver- 100BASE or 1000BASE optical convector.

Attention

Note that apply 100Base SFP module into the device with 100Base-SFP WAN interface. Similarly, ensure that apply 1000Base SFP module into the device with 1000Base-SFP WAN interface. Please find the exact WAN interface on the label of outer box or on the bottom of device for the specification of your router.

- * Note 1: For WPS configuration, please refer to the WPS section of User Manual.
- * Note 2: Please refer to the instructions on the label of the outer box or on the bottom of the device to get the specification of your router

Hardware Connection

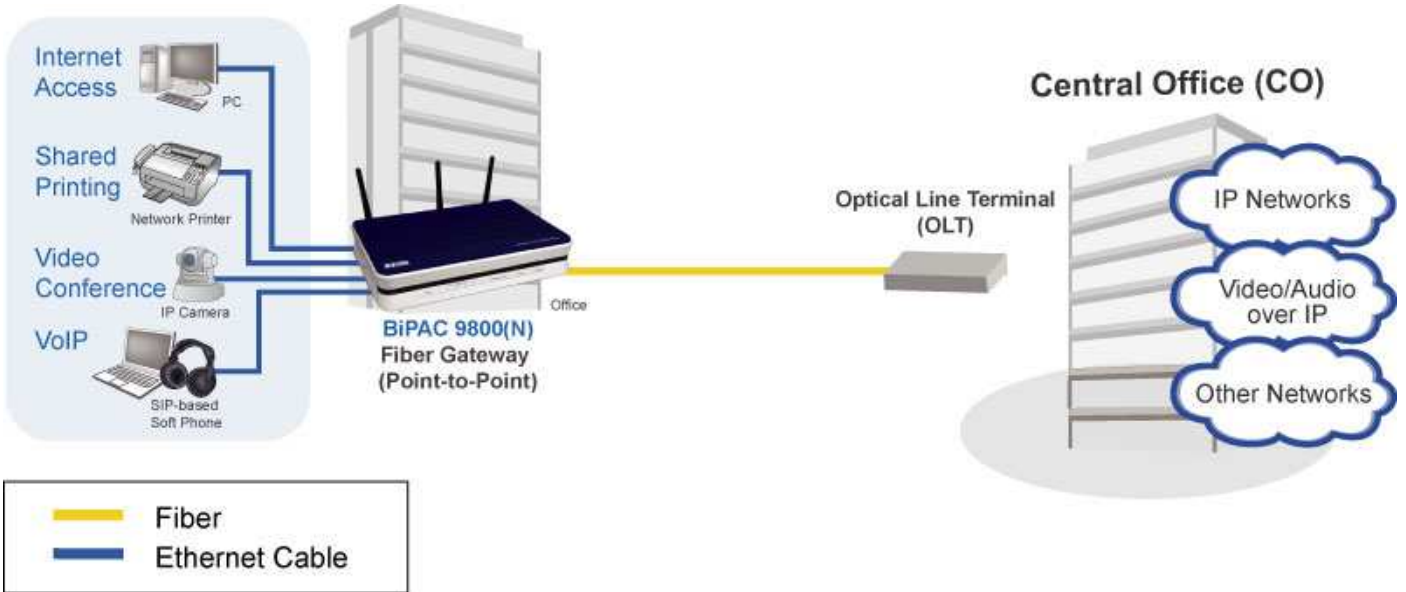

Hardware Installation

1. Power Connection

Plug the supplied power adapter into the wall jack and the other side to the router. Please note that the plug type may differ according to country.

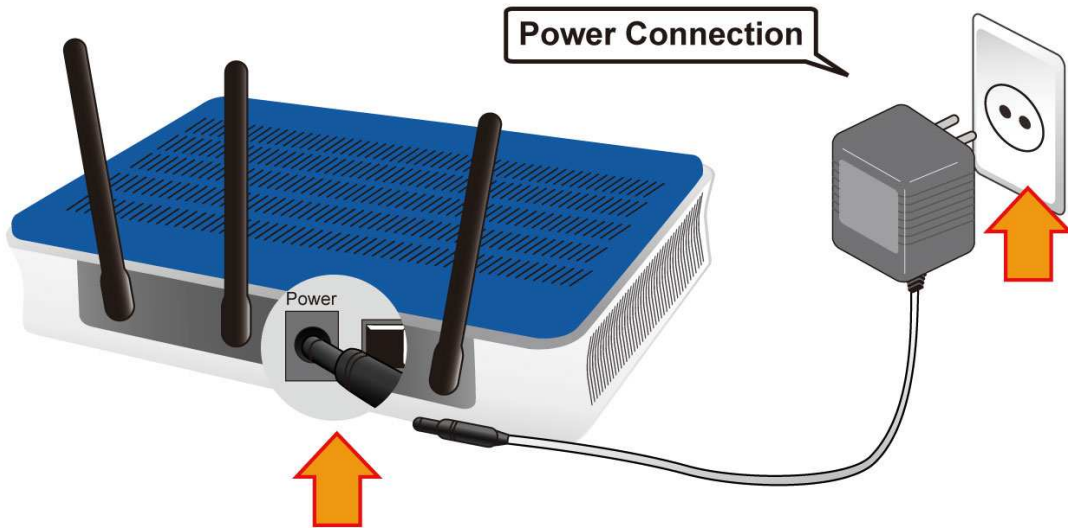

2. LAN Connection

Connect the supplied RJ-45 Ethernet cable to one of the Giga Ethernet ports, and the other side to the PC's Ethernet interface.

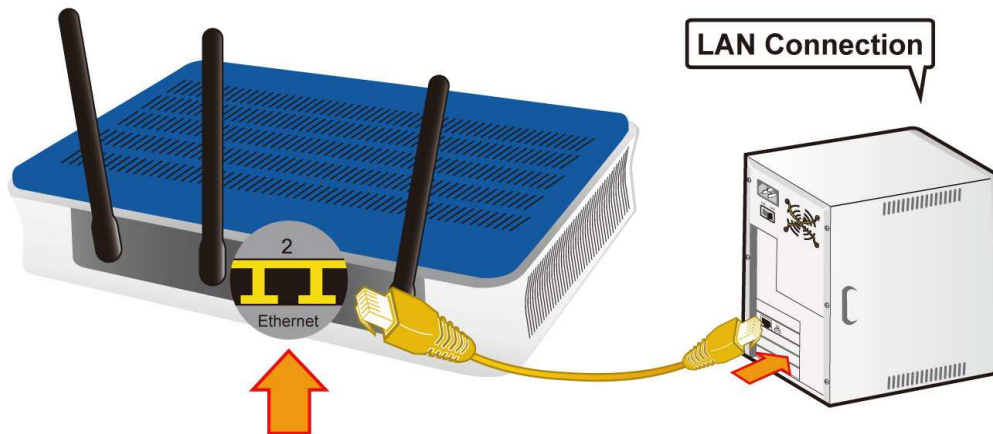

3. Fiber Connection

Please follow the illustrations below to connect the fiber cable or module and the router.



Attention

The type of fiber interface varies from device models provided by your ISP. Please find the exact WAN interface on the label of outer box, or label of the bottom of device for the specification of your device. And follow the instructions of hardware installation corresponded to the device specification.



Warning

Please do not look steadily at the fiber port when you connect the fiber, because the invisible light may harm your vision.

a) BX

Insert the single fiber cable into the BX jack of the router.

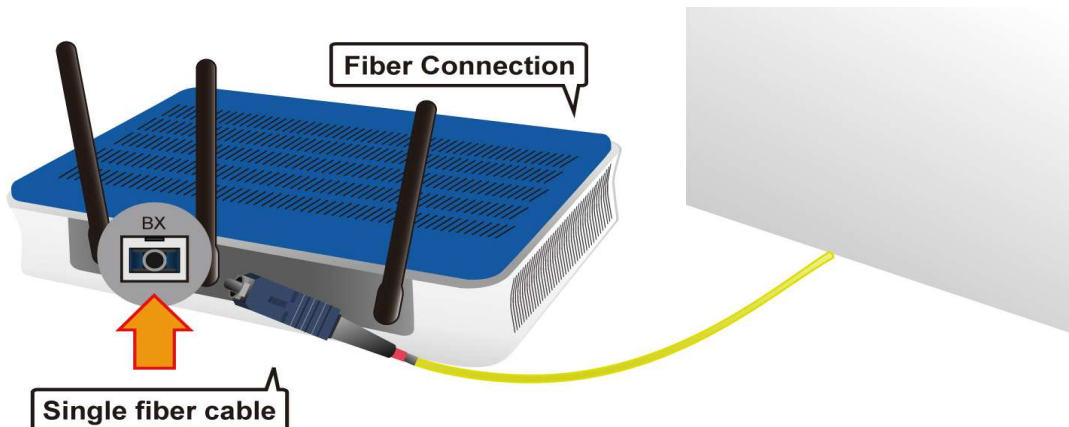

b) LX/ FX

Insert the dual fiber cable into the TX and RX jacks separately of the router.

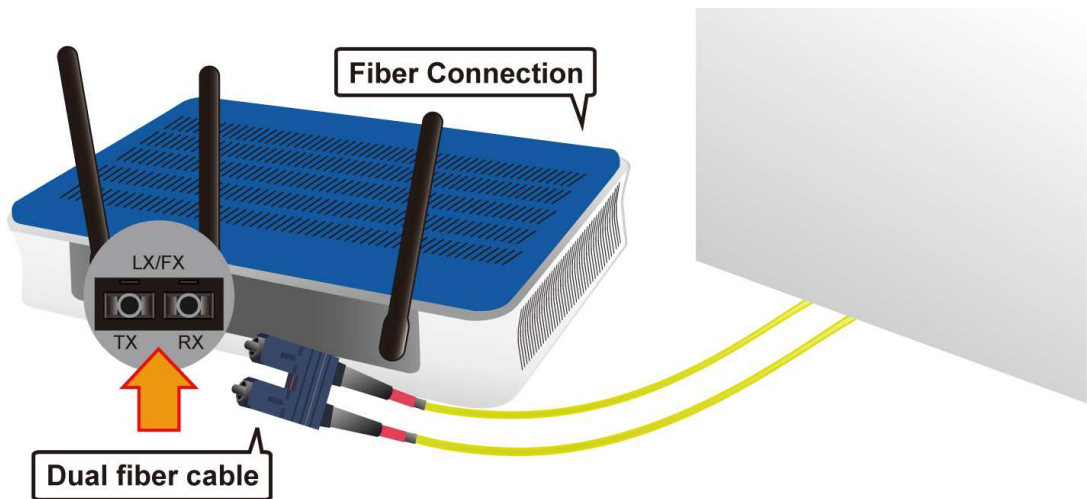

c) SFP

Set the Mini-GBIC module in the SFP port of your device, and then connect the fiber cable to the module.

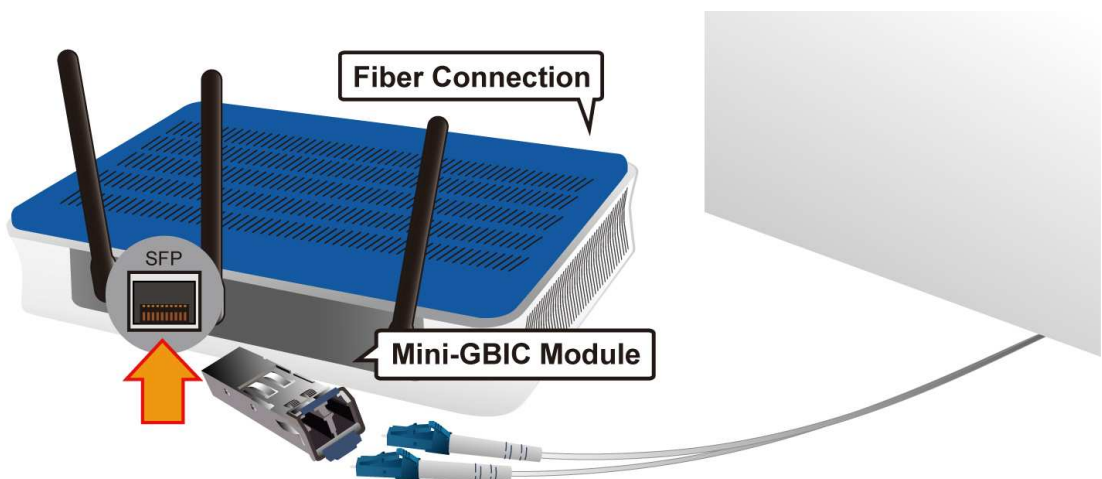

Connecting to the Router

1. Open the web browser and type `http://192.168.1.254` in the browser's address box. This number is the default IP address for this router. Press **Enter**.
2. A username and password window will appear. **The default username and password are admin and admin**. Press **OK** to proceed.
3. You will get a status report web page and main menu screen.

Please see the relevant sections of user manual for detailed instructions on how to configure your router.

Troubleshooting

1. None of the LEDs lit when the router is turned on.

Examine the connection between the router and the adapter. If the problem persists, most likely it is due to the malfunction of your hardware. Please contact your service provider or Billion for technical support.

2. You have forgotten your login username and/or password.

Try the default username & password (please refer to User Manual). If this fails, restore your router to its default setting by pressing the reset button for 1~2 seconds.

3. Cannot PING any PC on LAN.

Examine the Ethernet LEDs on the front panel. The LED should be on for the port that has a PC connected. If it does not light, check to see whether the cable between your router and the PC is properly connected. Make sure you have first uninstalled your firewall program before troubleshooting.

4. Fail to make fiber connection.

Ensure the fiber cable or the mini-GBIC module has been connected correctly and the fiber cable has not become damaged or bent. Ensure that you apply right fiber cable(s) into right port(s) and right SFP module into right device as well. If the problem persists, Please contact your service provider or Billion for technical support.

Product Support and Contact Information

Most problems can be solved by referring to the **Troubleshooting** section in the User Manual. If you cannot resolve the problem with the **Troubleshooting** chapter, please contact the dealer where you purchased this product.

Contact Billion

WORLDWIDE

<http://www.billion.com>

Billion Product Registration

Billion is committed to before and after sales customer services. You will get the most out of your Billion's products after registration. Please register online at <http://www.billion.com/register> to receive valuable services and support from us.